

OBJECT	armchair
CODE	R
DIMENSIONS (height x width x depth)	104 x 76 x 62 cm
QUANTITY	1

PHOTOS

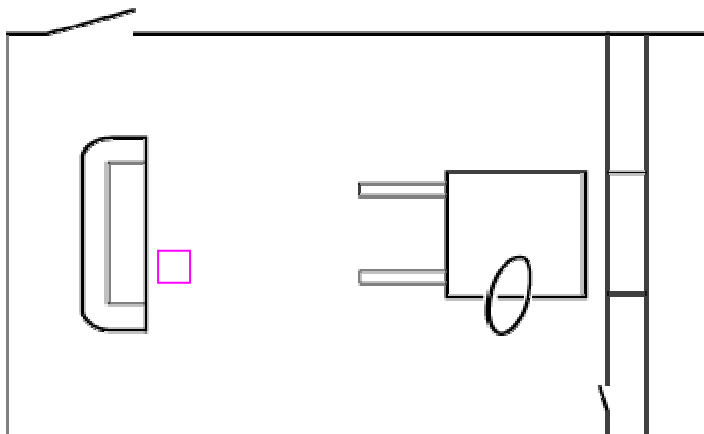

POSITION IN THE INSTALLATION SPACE



DESCRIPTION	The armchair is made of wood. The structure is composed of a textile net and metal springs. Some ropes hold the spring. There is no upholstery on it.
CONDITION	The object is old. There are some loose splinters and holes caused by woodworm (now in stable condition).
PREVENTION AND PRESENTATION GUIDELINES	The armchair is placed in front of the sofa. The position is not fixed.

OBJECT	audio materials
CODE	N2 (mixer); N3 (amplifier); N9 (radio); N11 (contact microphone); Q (audio box)
DIMENSIONS (height x width x depth)	N2: 6.5 x 31.5 x 20 cm N3: 12 x 43 x 27 cm N9: 11 x 38 x 22.5 cm Q: 22 x 15 x 16 cm
QUANTITY	N2, N3, N9:1 N11, Q:2
PHOTOS	    
POSITION IN THE INSTALLATION SPACE	The audio boxes are placed on the side of the direction box. The mixer and the amplifier are on the first level of the control box; the radio on the third. The contact microphone is connected to the mixer.

N2

N3

N9

N11

Q

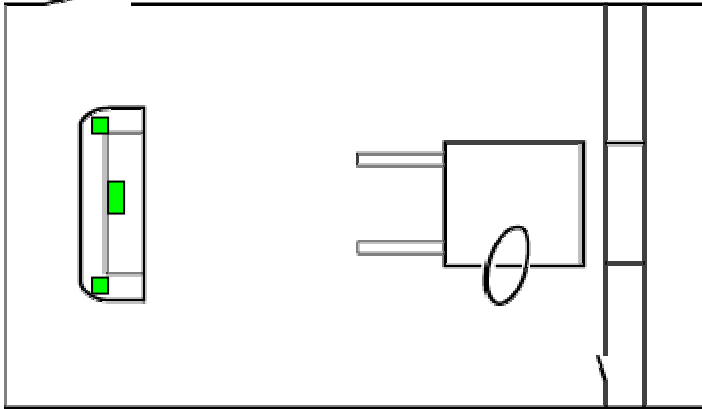

DESCRIPTION

N2: "REALISTIC" (trade name) stereo audio mixer, model NO. 32 - 1210, AC 220V, 50Hz, 10W.
 N3: integrated stereo amplifier SONY (trade name), model no. TA - F 170, AC 220 - 230V, 50 - 60 Hz.
 N9: stereo tuner AKAI, AT 2200, 110-240V, 50-60Hz, 10W.
 N11: contact microphone: PIEZO TRANSDUCER 30V, 0.5-20 Hz, 75 dB (sound pressure level), lead type (Vellemans production).
 Q: black audio boxes JB system, 70-20 kHz (frequency), 8 ohms, max 70W.

CONDITION

The objects are in good condition. They were dusty. The dust was removed with a soft brush. A cable from the mixer is damaged.



In the conservation department there is an extra fuse for the radio stereo.

PREVENTION AND PRESENTATION GUIDELINES

The objects can be replaced by a similar model with similar characteristics. A crate must be constructed for them. The contact microphones are placed on the different objects with white tape. Use the least number of microphones possible. Four new contact microphones have been purchased and are now being stored in the conservation department of the museum. The further purchase of extra contact microphones at the present time would facilitate their replacement in the future. These microphones are produced by Velleman. Their file is in the archive.

OBJECT	inscription "BEGIN"
CODE	C
DIMENSIONS (height x width x depth)	variable
QUANTITY	1
PHOTOS	



POSITION IN THE INSTALLATION SPACE It is placed on wall no. 4, close to the electrical wires (see diagrams).

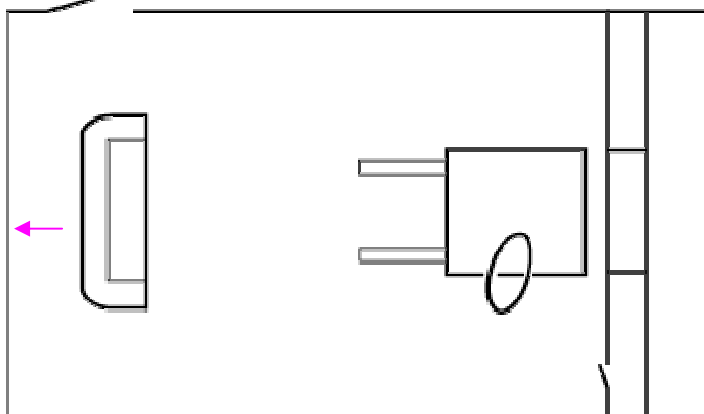

DESCRIPTION The word BEGIN is marked with black color on a piece of grey colored DUCK tape. DUCK tape has a textile structure that makes it especially strong.

CONDITION

PREVENTION AND PRESENTATION GUIDELINES The object is used during the performance. Its position has been changed for wall 2 to wall 4. In this position it is more easily seen by the performer during his actions. The object is new with every new installation.

OBJECT	bike
CODE	V
DIMENSIONS (height x width x depth)	110h x 182w cm
QUANTITY	1
PHOTOS	



POSITION IN THE INSTALLATION SPACE

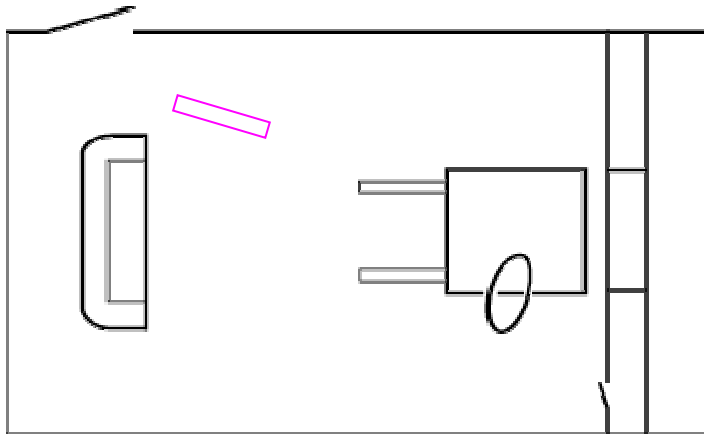

DESCRIPTION	It is a blue, 5-speed city bike, with the name "Granada" on it.
CONDITION	The metal parts are rusted. The bike is dusty and dirty.
PREVENTION AND PRESENTATION GUIDELINES	It is possible to replace the object.

OBJECT	box with accessories
CODE	D (1 to 8)
DIMENSIONS (height x width x depth)	D (box): 100 x 150 (+ 90 cm train structure) x 152 cm (no. 1); 92 x 149 x 122 cm (no. 2 under) D1 (honey-clock): 65 cm h and 20 cm diameter D2 (Lego train): 65 cm length and 5 cm width D3 (curtain for Lego train): 37.5 x 19 cm D4 (curtain for window box): 65 x 69 cm D5 (inscription): 6.5 x 20 cm (one element) D6 (foot bench): 48.5 x 18.5 x 8.5 cm D7 (pillow): 56 x 30 cm D8 (lamp): 35 cm diameter
QUANTITY	D:1 D1:1 D2:1 D3:1 D4:1 D5:6 pieces D6:1 D7:1 D8:1

PHOTOS



front



window





train



speed regulator



lamp

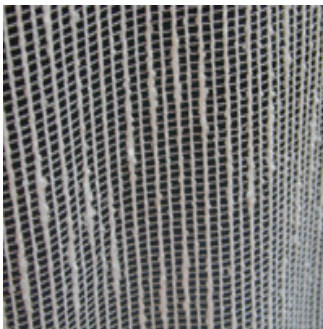

curtains



honey-clock



Lego train

POSITION IN THE INSTALLATION SPACE

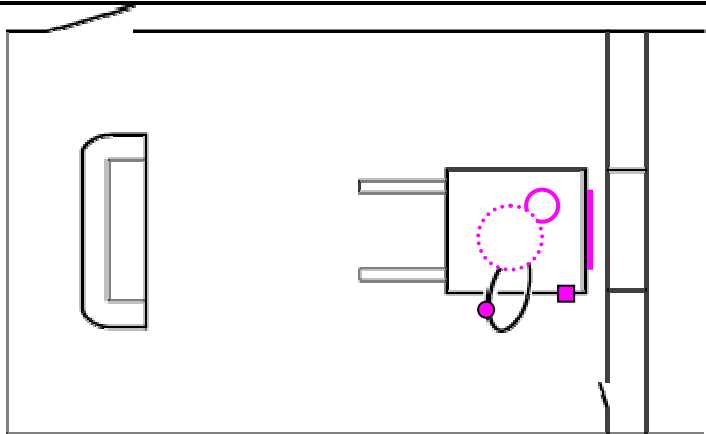
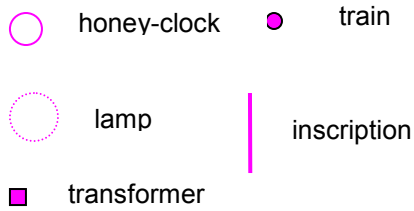

The foot benches and the pillow are placed under the box.

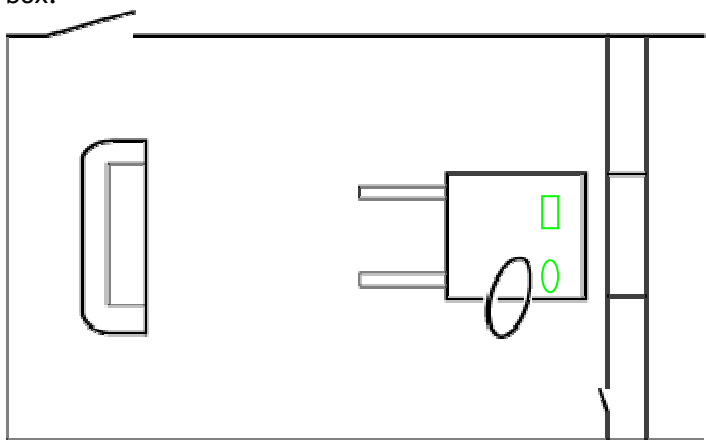

DESCRIPTION

The box is composed of two parts. The lower part has wheels to move along the guide strips. The upper part is open on one side, through which it is possible to see the objects and the actions inside during the performance. The hourglass is placed in the upper part. There is a hole in the base of the upper part, through which the performer can stick his head into the box. On the top edges of the box there are 12 metal hooks on which the inscriptions can be hung. On the back side there is an opening with a shutter and a curtain, as well as two metal handles to be used to move the box. On the left side of the box there is an opening for a wooden structure for the train. On this structure the railway for the train is nailed. Outside is placed the speed regulator for the train.

The box is made of plywood.

D1: the hourglass is composed of two parts that are glued together and filled with honey (acacia).

D2: a lego train composed of two parts colored yellow and black. It is a Lego system model no. 4559, 1996. The electric train motor is the Lego model no. 5300 (old catalogue 1999, new no. 10153 (bef.1.345/f.7.20)). The speed regulator is model no. 4548 9V Lego system. The railway is the no. 4531 Lego model. The train has a black device to recharge the battery.

D3 and D4: white perforated curtains: one to put on the train during the performance, one placed on the window.

D5: white water based acrylic color inscription on fiber

	<p>plates (erscheinen ist nicht elegant). D6: wooden foot bench. D7: half-moon shaped pillow. The back is grey colored, the front is knitted (rainbow colors). D8: metal lamp (silver color) placed on the top of the box (40W).</p>
CONDITION	<p>The objects are in good condition. The old train's motor and two "rechargeable battery" devices are in the S.M.A.K. Conservation Department.</p>
PREVENTION AND PRESENTATION GUIDELINES	<p>The box has fixed measures. It is the first thing placed in the room and the window in the room's wall is built in conformity with it. It is placed on a railway on the floor and moves by wheels (4). The lamp is placed on the top. There is a 40W lamp which the artist would like to exchange for a 100W lamp. It is advisable to buy a new Lego train and accessories to replace the original in the future. The hourglass is filled with acacia honey colored with Ecoline colors. The acacia honey is more liquid and durable and will become sugar only after many years compared to other kinds of honey. The two parts have been glued with an adhesive that becomes hard under the effect of UV rays. All the objects can be replaced. To move the installation, it would be necessary to build a crate for the different objects. For the hourglass a crate similar to that of the water-oil clock is a good solution. The Lego train requires a crate of its own. The transformer is nailed to the box.</p>

OBJECT	“coffee table” and accessories
CODE	I (1 to 9)
DIMENSIONS (height x width x depth)	I (table): 45.5 x 100 x 50 cm I1 (coffee maker): 27 x 29 x 12 cm I4 (alarm clock): 8.5 cm diameter I5 (water-oil clock): 25 cm h.; 15 cm diameter
QUANTITY	I:1 I1:1 I2:2 I3:5 I4:1 I5:1 I6:1 I7:1 I8:1 I9:1

PHOTOS



POSITION IN THE INSTALLATION SPACE	The cup is placed on the table and the filters and individual coffee creamer servings under it. The cards are placed on the table during the performance;
------------------------------------	---

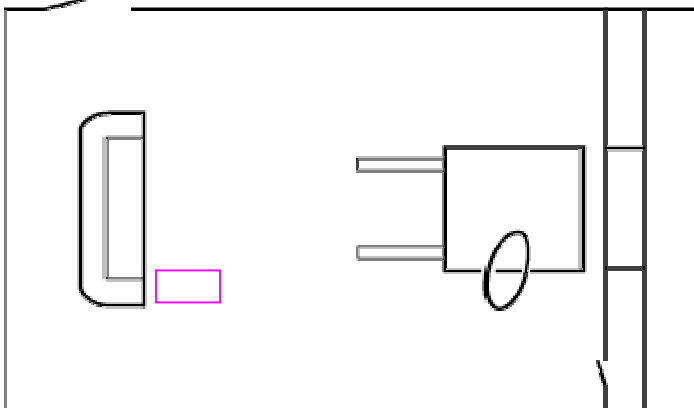

Position on the table

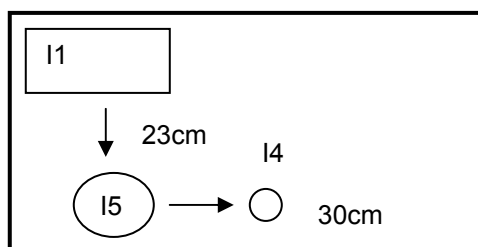

DESCRIPTION	<p>The table is a wooden structure with a fiberboard base for the objects. This base has a similar wood pattern. On the table there are different objects:</p> <p>I1. old style coffee maker composed of yellow and brown plastic and glass and metal (VEB Elektromechanik, Berlin - Kaulsdorf DDR, Kaffee - Tee - Automat K 109, 800W, 220V).</p> <p>I4. old style metal clock.</p> <p>I5. hourglass composed of two glued parts and filled with oil and water. The time mechanism depends on the volume and weight of the content.</p> <p>I6. white ceramic cup with words printed on it (anyone seen my cash cow?.. and a coffee brand logo).</p> <p>I7. Package of coffee</p> <p>I8. white thermos with some red and yellow drawings on it.</p> <p>I9. small plastic yellow coffee measuring spoon.</p>
CONDITION	<p>The table is old and worn, especially on the edges, where there are also some loose splinters. It is dirty, there are some coffee spots on it. The coffee maker is dirty. The metal clock does not work. In the hourglass there are some stains of solid oil. It was broken and the two parts came unstuck. It was then glued back together with a two-component epoxy resin (Araldite 2020).</p>
PREVENTION AND PRESENTATION GUIDELINES	<p>The performer ('spullenbaas' or Chief of Objects) places the cards on the table during the performance. If he wants, he can put a lamp on the table to read the cards easily.</p> <p>The position of the objects on the table has been established in consultation with the artist because the</p>

heat from the coffee maker was a problem, mainly for the hourglass. All the objects can be replaced. The adhesive on the hourglass is reversible. The oil inside the hourglass is salad oil. The time mechanism can be reproduced by calculating the weight and the proportion of the different content (water and oil) of the clock. The coffee maker is an old system and fashion style and it is important to have the same system in the future in order to have the same kind and quality of sound. The oil-water clock is in a wooden crate. It would be better to create a new crate in which it would be possible to open the side to manipulate the objects. It is necessary to build a crate for the table and for the cup, the can and the clock. The other objects are new with every new installation.

OBJECT	Control box; wooden structure
CODE	N;N14
DIMENSIONS (height x width x depth)	N (control box): 100 x 85 x 75 cm (73.5 x 85.5 cm the kitchen towel) N14 (wooden structure): 110 (with wheels) x 201x 82 cm
QUANTITY	N,N14:1

PHOTOS



POSITION IN THE INSTALLATION SPACE

The sofa is placed on the wooden structure.

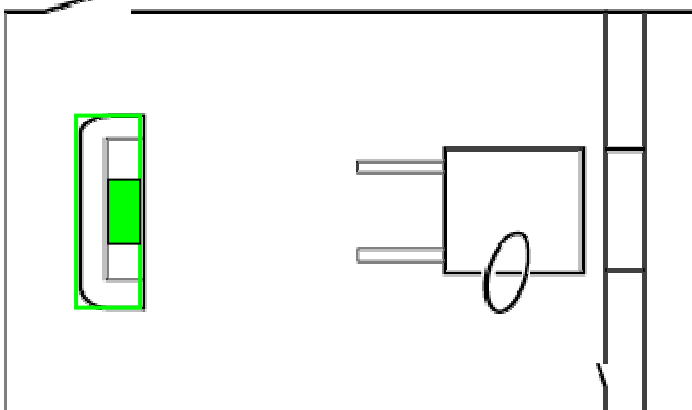

DESCRIPTION

The control box is an MDF (multi-density fiber board) box

	<p>with three levels. To cover the objects, there is a Scottish pattern kitchen towel (red and white), fastened to the front of the box with white drawing pins. The wooden structure is composed of different wooden beams and it moves on four wheels.</p>
CONDITION	<p>The objects are in good condition.</p>
PREVENTION AND PRESENTATION GUIDELINES	<p>The kitchen towel does not completely cover the objects in the control box. It is always possible to see the paraphernalia that the performer uses during the performance, and tape, bags, etc., that are placed under the control box. This is not a problem for the artist.</p>

OBJECT	curtain
CODE	G (from 1 to 9)
DIMENSIONS (height x width) The width is that of the curtain exposed (not the maximum).	G1: 140 x 150 cm; G2: 152.5 x 58 cm; G3 244 x 157 cm; G5 111 x 180 cm; G6 216 x 111 cm (tot); G7 142 x 160 cm; G8 138 x 133 cm max (one part); G9 h 123 cm
QUANTITY	8 different curtains (7 for room B, one G8 for space C), one wooden bar to move them (G9).

PHOTOS



wall1



G2 (short)



G3 (long)



G7



wall3



G6



G5



G4



G1



G8



G9

POSITION IN THE INSTALLATION SPACE

wall 1
 From G1 to G7 are placed on the walls of the room B.
 wall 1: G3, G2, G7
 wall 3: G1, G4, G5, G6

G8 is hanging in the space C

G9 is put on the shirt stand

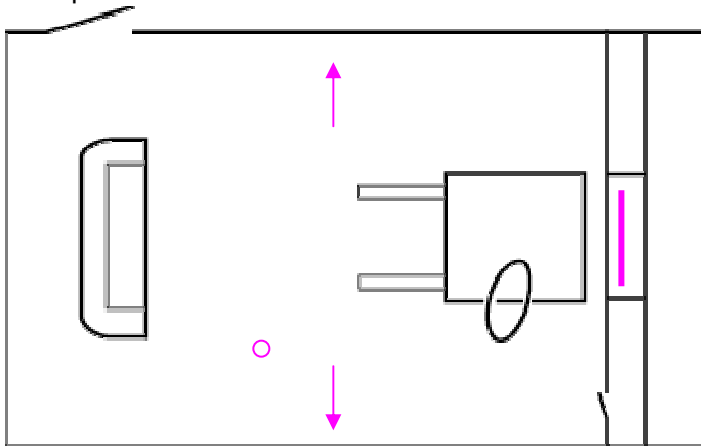

wall 3

DESCRIPTION

All the curtains are placed on a wooden circular bar that is hung up the wall, on metal square hooks. G7 is tied to a wooden bar with nylon ropes. The curtains are placed on the wall and on the railway by a small wooden bar during the performance. G8 is placed on a wooden structure in space C (2.50 m longer).

G1: white perforated curtain

G2: short white curtain
G3: white curtain with a red stitching on the top
G4: Scottish pattern curtain (with red, green and blue lines) composed of two cut pieces.
G5: short velvet curtain with a red and blue flower pattern.
G6: green and violet pattern curtain.
G7: PUR foam curtain, with word inside.
G8: red velvet curtain composed of two parts.

CONDITION

All the curtains are dirty. There are some spots on G3 and G4. G6 is very dusty on the back side. G7 is broken in different parts; it was glued to be used during the installation; some parts are lost, mainly on the edges.

PREVENTION AND PRESENTATION GUIDELINES

G7 has to be replaced. The artist gave the order to do so and made a new curtain together with us. A film was made of this process (S.M.A.K. archive) and the artist gave the instruments used in the process to the museum. This video provides all the instructions that are necessary for creating a good curtain.
The PUR curtain can be remade anytime this may be necessary. If so desired, the artist can also make a new PUR curtain with every new installation.
The words written on it were determined by the artist. You can write wherever you want but the text is set: YOU....BECAUSE...YOUR....LITTLE...DOG....KNOWS...YOU.
The writing must be fit into the space below the fourth line from the top and above the last line of the curtain.



new PUR curtain (060318)



It was necessary to use two screws on the wooden bar to place G7 on the rail.

The curtains can be washed, though this is not necessary at the current time. Only the brown stains on G3 need to be removed.

They can be stored, rolled (not folded) and covered with an acid-free tissue or a sheet of Tyvek in a wooden crate. The PUR foam fits into a rectangular wooden crate and is placed in it on an ethafoam sheet. The crate is covered inside with ethafoam. This crate is a good solution for transporting the curtain.

OBJECT	Doll-beast
CODE	M
DIMENSIONS (height x width)	32.5 x 28 cm
QUANTITY	1

PHOTOS



POSITION IN THE INSTALLATION SPACE

The doll-beast can be placed on the sofa or on the Tomatentraum table at the end of the performance. During the performance, the doll can also be placed on the railway (overhead rail).

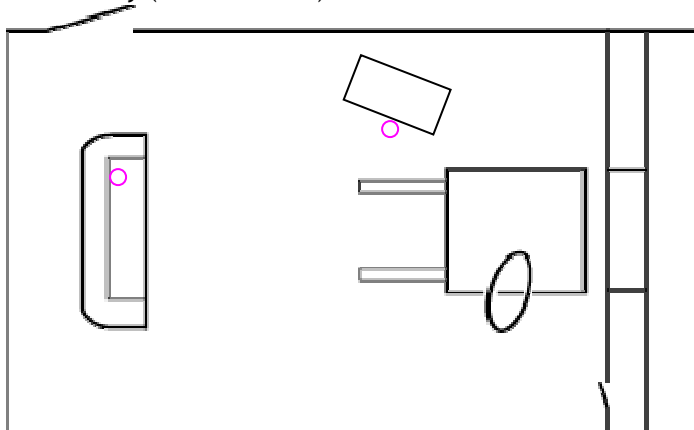

DESCRIPTION

The doll is composed of a human body with plastic arms and legs and a cuddly animal toy head. The head is sewn onto the body and turned to the right side. There is a little plastic clip on the head to place the doll on the railway (overhead rail) or on the Tomatentraum table during the performance.

CONDITION

The doll-beast is in generally good condition, though it is dirty, and on the body there are some black spots.

PREVENTION AND PRESENTATION GUIDELINES

It is possible to wash the doll. It is possible also to recreate the object in a similar shape, colors and materials.

The doll can be packed in a Tyvek sheet and placed in a wooden crate.

OBJECT	door
CODE	C (room A); Z; Z1
DIMENSIONS (height x width x depth)	C, Z: 200 x 105 x 4 cm Z1(cardboard): 30 x 52.5 x 4 cm
QUANTITY	C:1 Z:2 Z1:1

PHOTOS



POSITION IN THE INSTALLATION SPACE

The object shown in the diagram is the cutout section of the hollow door that can be used to close the opening in the door.

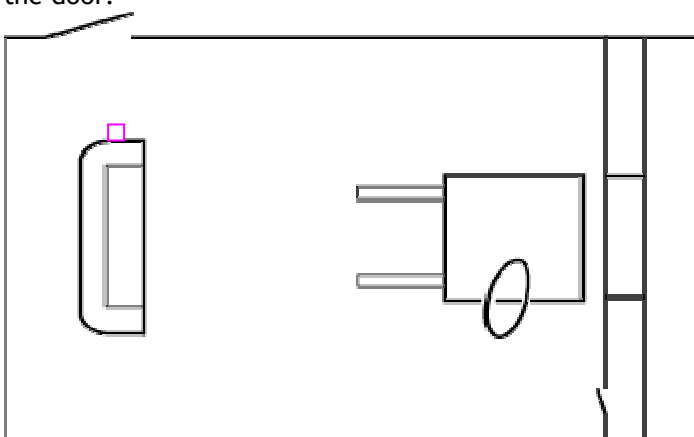

DESCRIPTION

The doors (room A and B) are made of wood, reinforced hollow door construction material and metal (handle, hinge). The device for opening and closing the door is made of metal.

CONDITION

The objects are in good condition.

PREVENTION AND PRESENTATION
GUIDELINES

It is possible to use these doors for a new installation.
The cutout section of the hollow door is used to close the
opening in the door of room B during the performance. It
can be placed under the ladder when it is not being used.

OBJECT	Incubator and carpet
CODE	E (incubator) - F (carpet)
DIMENSIONS (height x width x depth)	E: 42 x 32 x 40.5 cm; F: 86 x 36.5 cm
QUANTITY	1 incubator; 1 carpet
PHOTOS	



incubator



carpet pattern



thermometer



lamps

POSITION IN THE INSTALLATION SPACE The carpet is placed under the incubator.

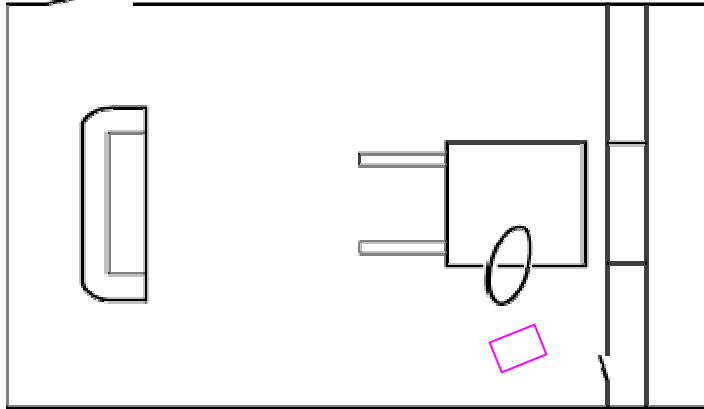

DESCRIPTION

E: a half-oval shaped wood structure covered with nailed white Formica® sheet (outside) and nailed sheet metal (inside). Inside on the top there are six light bulbs (5 100W, one 60W). Outside on the top, close to the metal handle, there is an old thermometer placed in a black plastic structure. From one of the short side starts a wire (no. 3).

F: Persian style carpet with geometrical and flower patterns (on a red background) and a colored fringe on the short sides.

CONDITION

E: It is dusty and dirty. There are some scratches on the wood and some spots and gaps on the Formica®. One of the light bulbs is missing. The short sides are de-assembled. The metal is rusted.

F: It is in good condition - just dusty and dirty. The objects have been cleaned with a soft brush to remove the dust.

PREVENTION AND PRESENTATION GUIDELINES

The artist would replace 60W bulb with a 100W bulb. The lost light bulb has to be replaced. The rusting of the metal has to be controlled.

The incubator and the carpet are always together: as objects, they are a "couple".

OBJECT	IR lamp
CODE	S
DIMENSIONS (height x width x depth)	24 x 15 (diameter) x 22.5 cm
QUANTITY	1
PHOTOS	



POSITION IN THE INSTALLATION SPACE

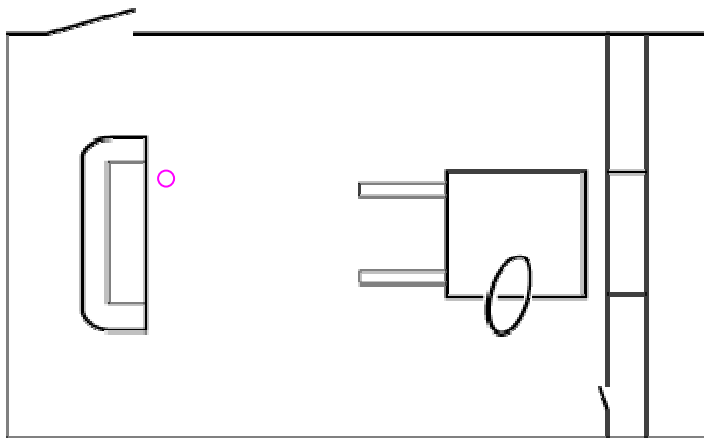

DESCRIPTION	This is a red IR lamp made of glass and metal. The body of the objects is sand coloured with a metal paint.
CONDITION	The object is in good condition. It is dusty and dirty and there are some scratches on the metal coating.
PREVENTION AND PRESENTATION GUIDELINES	The IR lamp is placed in front the projector. It always needs to be placed in the direction of the control box's curtain.

OBJECT	Ladder with accessories
CODE	U (1 to 4) for U1 see video material
DIMENSIONS (height x width x depth)	U (ladder): close 199 x 55 (max) x 18 cm U4 (cardboard): 27.5 x 52.5 x 5 cm
QUANTITY	1 ladder; 2 clamps; 1 hooks; 1 cardboard

PHOTOS



POSITION IN THE INSTALLATION SPACE

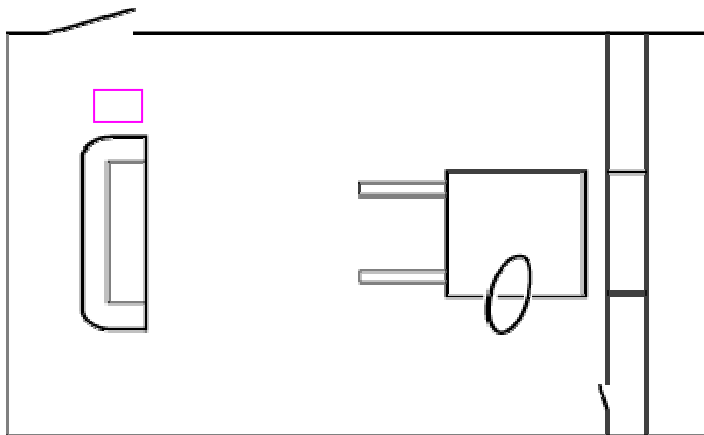

DESCRIPTION	The ladder is made of wood and metal. A TV monitor platform made of a cutout section of a reinforced hollow wooden door is fixed on the ladder with two metal clamps. A metal hook is hung on the ladder.
CONDITION	The ladder is dusty and dirty. There are different spots of paint on it. The metal parts are rusted. The other objects are in good condition.
PREVENTION AND PRESENTATION GUIDELINES	Each object can be replaced.

OBJECT	Light control panel
CODE	N4
DIMENSIONS (height x width x depth)	13 x 50.5 x 60 cm
QUANTITY	1

PHOTO

(See also electrical system in 2.2. Present installation, S.M.A.K. 2005 - 2006, text)



POSITION IN THE INSTALLATION SPACE

In the control box (second level).

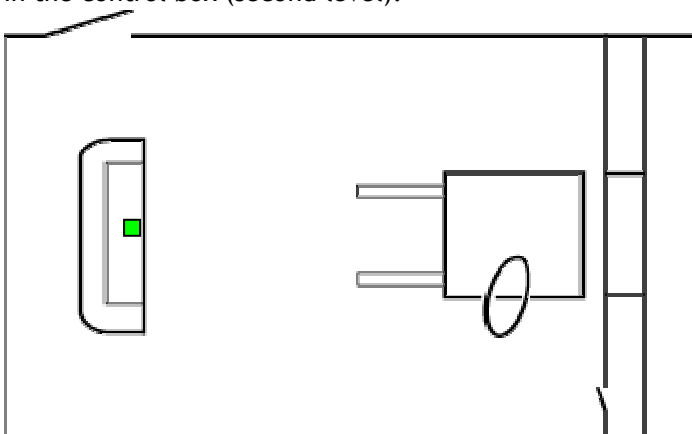

DESCRIPTION

The light control panel is an old wooden box with 10 white sockets and 8 black side switches (to regulate the lights) on it. There are also 10 white switches.

CONDITION

The panel is in good condition. It is dusty and it is an old system. The slide buttons are old and difficult to use correctly. They do not allow good regulation of the light during the performance.

The dust has been removed with a soft brush.

PREVENTION AND PRESENTATION GUIDELINES

The artist said that it is possible to replace the control panel with a new one to allow easier regulation of the lights. It would be good to construct a modern and easier to operate device.

OBJECT	plastic bag
CODE	W
DIMENSIONS (height x width x depth)	
QUANTITY	1
PHOTO	



POSITION IN THE INSTALLATION SPACE

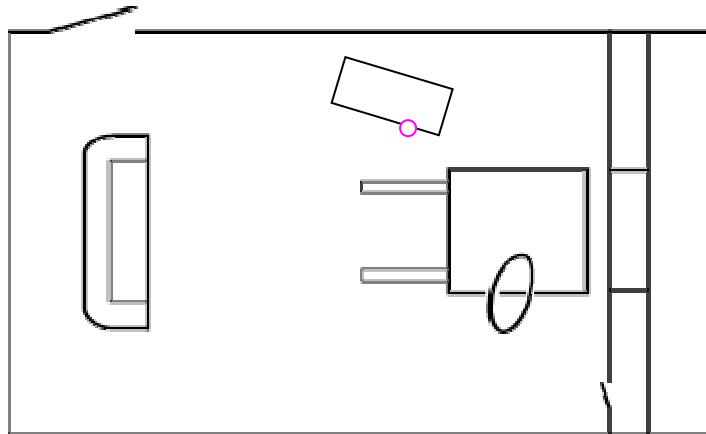

DESCRIPTION	Small white plastic bag, quite transparent and with any print whatsoever on it.. Inside the bag there are some und boards.
CONDITION	There are some tears in the bag.
PREVENTION AND PRESENTATION GUIDELINES	It is possible to replace the plastic bag. It is important for the artist to use a white, somewhat transparent bag with any print whatsoever on it and of the same shape. It is also important to put something in it to give a sense of weight. The und boards are a good solution for the artist, because they are already present in the space in many ways. Some und boards must always be in the bag. The plastic bag can be folded and packed in a Tyvek sheet.

OBJECT	projector; slide; base
CODE	0 projector 01 slide 02 wood base 03 PUR sheets 04 wooden plates
DIMENSIONS (height x width x depth)	O: 33 x 34 x 16.5 cm 01: 5 x 5 cm 02: 27 x 43 x 15.5 cm 03: 14.5 x 30 x 2 cm 04: 18 x 40 x 2 cm
QUANTITY	1 projector; 80 slides; 1 wooden base; 19 PUR sheets; 3 wooden plates.

PHOTO



slide projector



slide



base structure

POSITION IN THE INSTALLATION SPACE

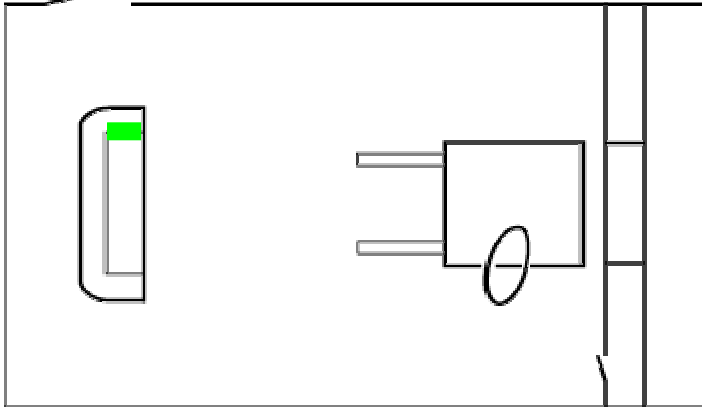

projector position

DESCRIPTION	<p>The projector is a Kodak extapro 5000, f/3.5 MC model with a zoom of 70-120 mm. It is the property of the S.M.A.K museum. It contains 80 slides. Some English and German words have been written on the slide by the artist with a red marker in italic type. The slides are projected in the middle of the window of the box. The projector rests on a support structure made with a wooden base, three wooden plates and 19 sheets of polyurethane rigid foam. The support structure is 40 cm high.</p>
CONDITION	<p>The objects are in good condition. They are dusty. The dust was removed with a soft brush. The colour on some slides is faded and the plastic mount is dirty.</p>
PREVENTION AND PRESENTATION GUIDELINES	<p>The projector must be pointed toward the box. The slides have to be projected in the window of the box. The position under the sofa is a good solution for the artist. The projector has to be inclined only slightly, because otherwise the projector will not work right. You could build a new support structure, but this support structure made with different objects that you can move and arrange seems to be a good solution.</p> <p>If some slides will be lost or damaged, it is possible to recreate it (see the list of the words of the slide).</p> <p>This model of projector is good for the artist. It is advisable to conserve it and other similar objects for the future, in case this one should be lost or damaged.</p> <p>It is advise to build a suitable crate. The walls of the crate have to be covered with ethafoam. The object for the base can be put in an other crate. The slides have been removed from the projector and are now placed in slide boxes.</p>

projector control



OBJECT	suspension rail
CODE	A railway; A1 hooks; A2 engine
DIMENSIONS (height x width x depth)	A: tot. length 21.14 m; A1 see the enclosure; A2 16 x 36 x 24.5 cm
QUANTITY	A: 1 object, 4 parts; A1: 40 hooks; A2: 1
PHOTO	

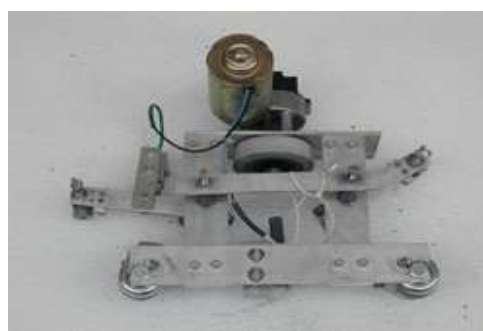

POSITION IN THE INSTALLATION SPACE

on the ceiling

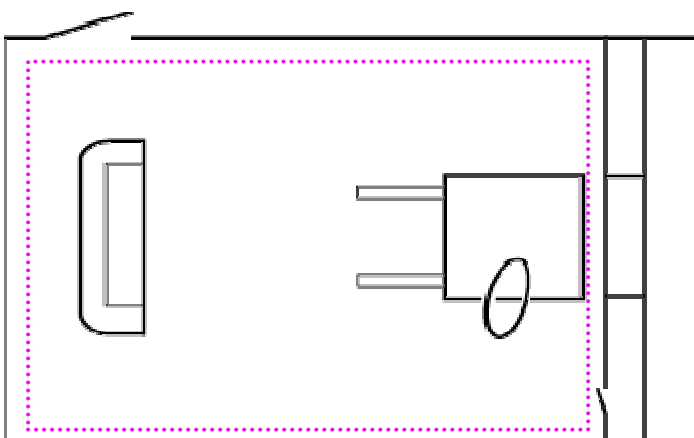

DESCRIPTION

The suspension rail is a metal structure (steel, copper) composed of 4 welded parts. Its moving parts are driven by an engine which is also installed on the ceiling. 40 metal hooks are hung on the rail. These hooks are used during the performance to hang up some objects. The rail is made by the MEYLAND company, and it includes some old parts. The engine is original, though some gears have been changed .
The direction and the speed of the movement is regulated by an electrical control located in the control box. The suspension rail is connected to the control box by an electrical wire (no. 7).

CONDITION

The suspension rail is in good condition. It was dusty and there is also a certain amount of metal dust created by the action of the hooks.



The copper was unwelded along the edges of the metal bar to remove the rail from the ceiling.
The dust was removed with a soft brush and vacuum cleaner.

PREVENTION AND PRESENTATION GUIDELINES

The distance of the railway from the ceiling is shown on the dimensions diagram. The hooks are marked with a number and a letter H for the shirt or a number and a letter G for the position of the curtain (see the enclosure). To install the curtains correctly, these positions must be respected. See the following text for the dimensions and positions of the hooks.

HOOKS:

Dimensions (there are six different dimensions):

2 meters: hooks no. 4, 7, 8, 12, 13, 16, 17, 18, 21, 25, 26, 30, 35, 37, 38

1.68 m: hooks no. 1, 5, 9, 10, 15, 24, 32

1.60 m: hooks no. 2, 3, 4, 19, 31, 34

1.18 m: hooks no. 11, 14, 18, 27, 28

1.20 m: hooks no. 6

0.94 m: hooks no. 20, 23, 33, 36

position of letter:

hook no.

3: G5

4 (two hooks): G5

5-6:H

9-10:H

11:G4

14:G4

15:H

18 (two hooks) - 19: H

20:G7

22:H

23:G7

24:H

27:G6

29:G6

31:G1, G2

32:H

33:G3

34:G1, G2
36:G3

Hooks no. 4 and 18 are composed of two hooks attached together.
Between no. 3 and no. 4 there are two places free (no hooks).
The engine is installed between no. 20 and no. 21.
Therefore between no. 20 and no. 23, for G7, there are the engine and two other hooks.
This arrangement has to be respected in order to install the curtains during the performance.

OBJECT	clothes stand with shirts
CODE	H, H1
DIMENSIONS (height x width x depth)	H:182 x 120 cm
QUANTITY	H:1 H1:14

PHOTOS



POSITION IN THE INSTALLATION SPACE

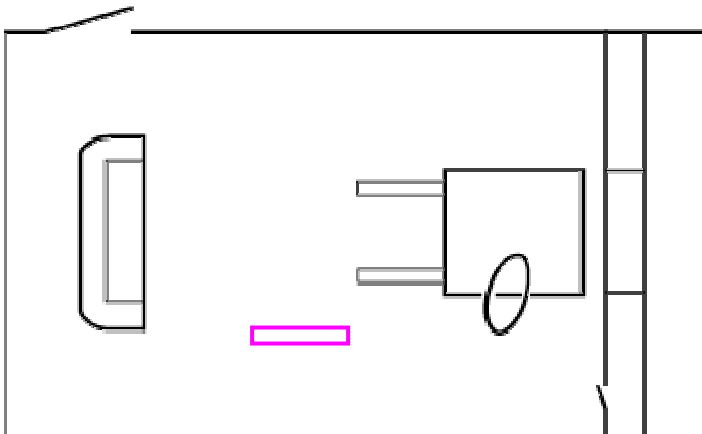

DESCRIPTION

The clothes stand is a wooden structure with a metal bar to hang the shirts on it. It is fastened to the floor with screws.

There are 14 different shirts on it. All are white.

No. 1: with flower lace on the shoulders.

No. 2, 7, 9, 13: women's shirt with short sleeves.

No. 3: with geometrical and flower embroidery on the front.

No. 4, 8: men's short-sleeved shirts.

No. 5: with flower embroidery and no sleeves.

No. 6: with blue buttons.

	No. 10: with sand colored embroidery on the front. No. 11: no sleeves. No. 12: with blue edging and gold buttons (5).
CONDITION	The shirts are dirty. The stand is in good condition.
PREVENTION AND PRESENTATION GUIDELINES	The shirts need to be washed and ironed. They are all hanged on the same type of clothes hangers. They are placed on common crutches. They can be placed in a crate covered with Tyvek sheets.

OBJECT	Sofa + light bike
CODE	L; L1
DIMENSIONS (height x width x depth)	L: 70 x 200 x 82 cm L1: 8 cm diameter
QUANTITY	1 sofa; 1 light
PHOTOS	



POSITION IN THE INSTALLATION SPACE

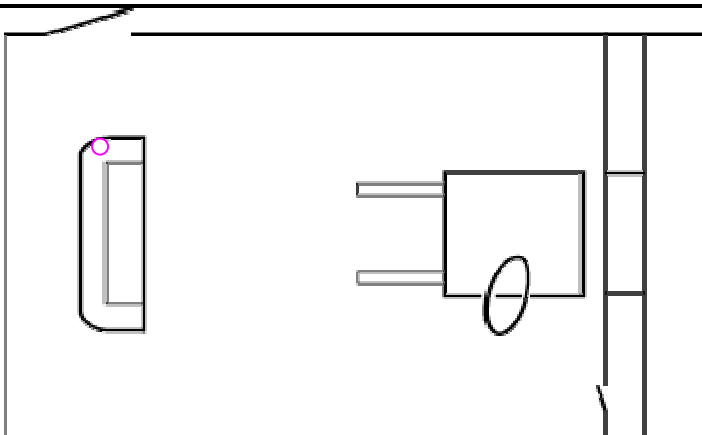

DESCRIPTION

The sofa is made of grey leather. There are no cushions on it. The sitting surface is black. The light for the bike is circular and made of black plastic.

CONDITION

Generally speaking, the objects are in good condition. The sofa is dirty and the leather is worn.

PREVENTION AND PRESENTATION GUIDELINES

The objects can be replaced. The sofa has been placed above the wooden structure. The small bicycle light is connected to the bike

OBJECT	standing lamp.
CODE	K
DIMENSIONS (height x width x depth)	h170 x 60 cm diameter
QUANTITY	1
PHOTOS	



POSITION IN THE INSTALLATION SPACE

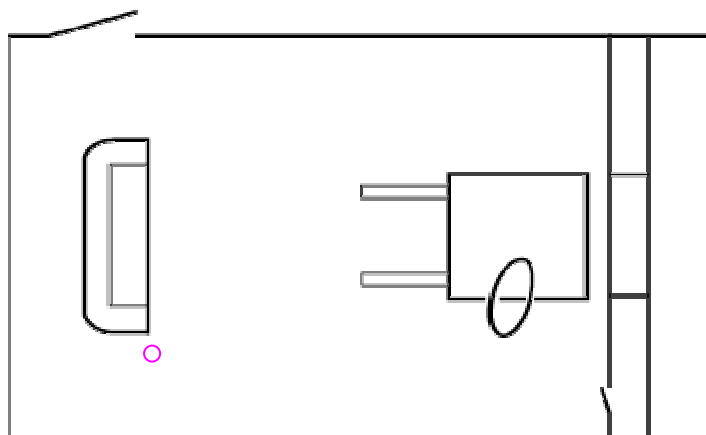

DESCRIPTION	The lampshade is made of a plastic material and the standard is made of metal (brass). There are some textile decorations on the lampshade.
CONDITION	The object is dusty and dirty. There are little tears in the plastic. The wire is old and worn.

PREVENTION AND PRESENTATION
GUIDELINES

The standing lamp can be replaced. The 40W lamp needs to be exchanged for a 100W lamp.

OBJECT	tomatentraum table
CODE	T (1 to 17)
DIMENSIONS (height x width x depth)	T (table): 76 x 110 x 75.5 cm
QUANTITY	T:1 T1 to 17: one sheet for each word. See the enclosure.

PHOTOS

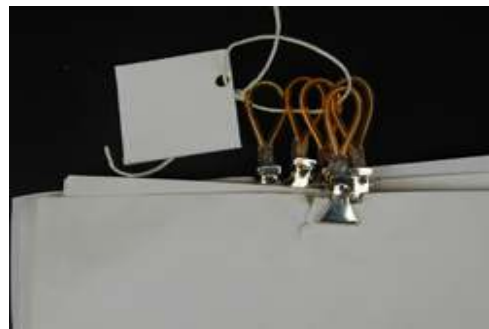
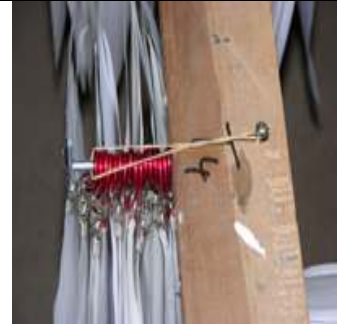

POSITION IN THE INSTALLATION SPACE

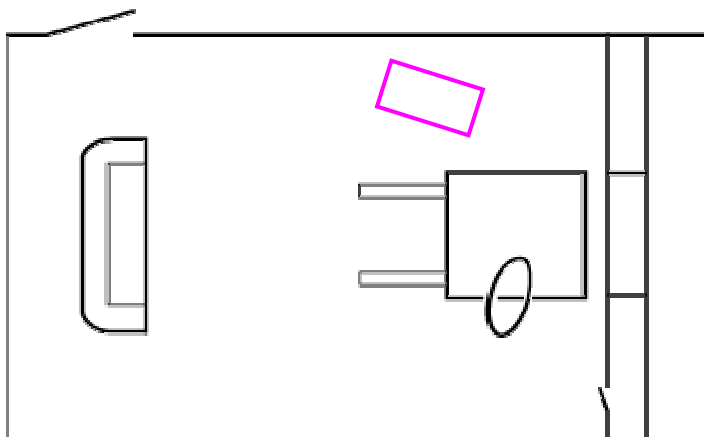

DESCRIPTION

Wooden table without a table top to put the objects on it. On the sides of the table, both outside and inside, there are a number of square metal hooks, upon which the sheets are hung.

	<p>On the inside, there are two hooks on each side. On the outside, there are 4 hooks on the long sides, 2 on one short side, and 3 on the other short side. Each hook is marked (with black marks on the table) and corresponds to one sentence (set of words).</p> <p>The words are written on white paper sheets (A4) with a black marker. The sheets are hung on the table by colored plastic and metal clips. There are 14 sentences of Tomatentraum and 3 other sentences.</p>
<p>CONDITION</p>	<p>The objects are in good condition. Some words are a bit faded and some sheets yellowed. There are some tears in the sheets caused by the clips.</p>
<p>PREVENTION AND PRESENTATION GUIDELINES</p>	<p>The position of the table was determined by the artist. The distances from the wall are shown on the floor plan (see room B floor plan, layer 5).</p> <p>The words can be written by the performer, if necessary. We have put rubber bands on the square hooks to secure the sets of word sheet) in place and to keep the visitors from moving them. It is also possible to mark the hooks with different colors so that the words can easily be put in their place. The text of Tomatentraum and of the sentences is in the booklets and should be translated into English.</p> <p>The paper sheets can be stored in an acid-free cardboard box. Each sentence (composed of different sheets) can be packed in acid-free silk paper. The hooks need to be placed in another type of packaging. It is not good to store the paper in contact with the metal of the clips.</p>

Tomatentraum 1, Zin 1, Zin 2 & Zin 3

This is the text of Tomatentraum and of the three sentences placed on the table.

Tomatentraum 1

Eine Ausstellung irgendwo in Köln, alle Menschen, die ich im Laufe meines Lebens kennengelernt hatte, waren in dieser Ausstellung ausgestellt. Sie standen an den Wänden, neben ihnen jeweils ein Schild mit Namen und dem Jahr in dem ich der entsprechenden Person begegnet war. Es war das erste Mal, dass sie alle beisammen waren. Eine Art Kordel begrenzte die 'Ausgestellten' mit dem Publikum, das auch nur aus 'Ausgestellten' bestand aus denen, die gerade pausierten. Zum pausieren konnte man einfach über die Kordel steigen und sich dann mit anderen unterhalten. Irgendwann, als es etwas ruhig war, hörte man das Quietschen von Autoreifen. Felix hatte sich in der Stadt verfahren und konnte die Ausstellung nicht finden an der er selbst auch teilnam. Ab und zu lief ein uraltes Mütterchen, das ich nicht kannte, quer durch den Raum mit einer Ladung alter Fensterläden unterm Arm, öffnete ein Fenster und schmiss die Fensterläden raus auf die Strasse, aus dem dritten Stock, was jedes Mal (die Aktion wiederholte sich in längere Abständen) einen ungeheuren Krach machte. Pit und Carola saßen gegenüber mit vorgebeugtem Oberkörper, jeder mit einem Blecheimer vor sich und einem Riesenstapel Tomaten neben sich. Jedes Mal, wenn sie sich selbst in eine kolossale Wut hineinsteigern konnten, ergriffen sie eine Tomate und schmissen sie in den Eimer vor sich dies jedoch ohne einen Laut von sich zu geben.

	1	2	3	4	5	6	7	8	9	10	11	12	13	14	15
T1	Tomatentraum 1	Eine	Ausstellung	irgendwo	in	Köln	Alle	Menschen	Die	ich	im	Laufe	meines	Lebens	kennengelernt
T2	waren	in	Dieser	Ausstellung	ausgestellt	Sie	standen	an	Die	Wänden	neben	ihnen	jeweils	ein	Schild
T3	Namen	und	Dem	Jahr	in	dem	Ich	der	Entsprechenden	Person	begegnet	war	Es	war	das
T4	Mal	dass	Sie	alle	beisammen	waren	Eine	Art	Kordel	begrenzte	die	Ausgestellten	mit	dem	Publikum
T5	auch	nur	aus	Ausgestellten	bestand	aus	Denen	die	gerade	pausierten	Zum	pausieren	konnte	man	einfach
T6	die	Kordel	Steigen	und	sich	dann	Mit	anderen	und	irgendwann	als	es	etwas	ruhig	war
T7	man	das	Quietschen	von	Autoreifen	Felix	Hatte	sich	in	der	Stadt	verfahren	und	konnte	die
T8	nicht	finden	An	der	er	selbst	Auch	eilnam	Ab	und	zu	lief	ein	uraltes	Mütterchen
T9	ich	nicht	Kannte	quer	durch	dem	Raum	mit	einer	Ladung	alter	Fensterläden	unterm	Arm	öffnete
T10	Fenster	und	Schmiss	die	Fensterläden	raus	auf	die	Straße	aus	dem	dritten	Stock	was	jedes
T11	(die	Aktion	Wiederholte	sich	in	längere	Abständen)	einen	ungeheuren	Krach	machte	Pit	und	Carola	saßen
T12	mit	vorgebeugtem	Oberkörper	jeder	mit	einem	Blecheimer	vor	sich	und	einem	Riesenstapel	Tomaten	neben	sich
T13	wenn	sie	Sich	selbst	in	eine	kolossale	Wut	hineinsteigern	konnten	ergriffen	sie	eine	Tomate	und

OBJECT	suspension rail control
CODE	N5; N6; N10
DIMENSIONS (height x width x depth)	N5-6: 14 x 21 x 36 cm; N10: 8 x 32 x 24 cm.
QUANTITY	N5 - 6 - 10: 1
PHOTOS	



POSITION IN THE INSTALLATION SPACE

in the control box (N 5 - 6 third level; N 10 second level).

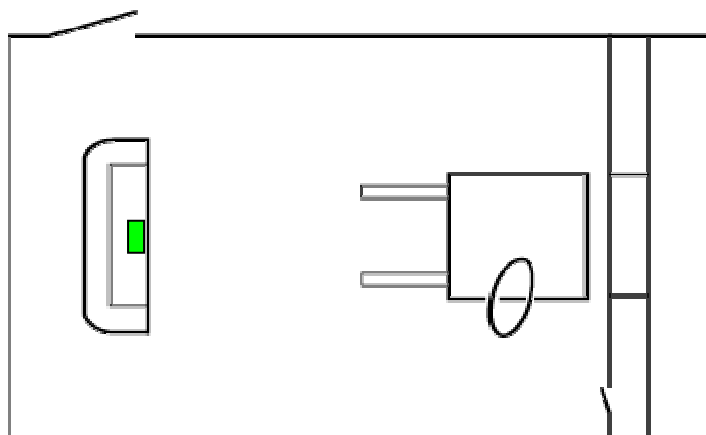

DESCRIPTION

The suspension rail control is composed of two devices fastened on a wooden plate with screws. One of the devices - wooden and rectangular in shape - regulates the direction of the suspension rail movement; the other is a circular metal device for regulating the rail speed.

	The control for the railway and the train is a black wooden box with 3 sockets and 3 switches on it (see the photo).
CONDITION	The objects are dusty. This is an old system. The dust was removed with a soft brush.
PREVENTION AND PRESENTATION GUIDELINES	The artist wants to conserve these devices in the future.

OBJECT	und boards
CODE	Y
DIMENSIONS (height x width x depth)	about 11 x 20 cm (each board is a little different)
QUANTITY	total 129
PHOTOS	

POSITION IN THE INSTALLATION SPACE

Some und boards are always placed close to the windscreen. The others are used during the performance.

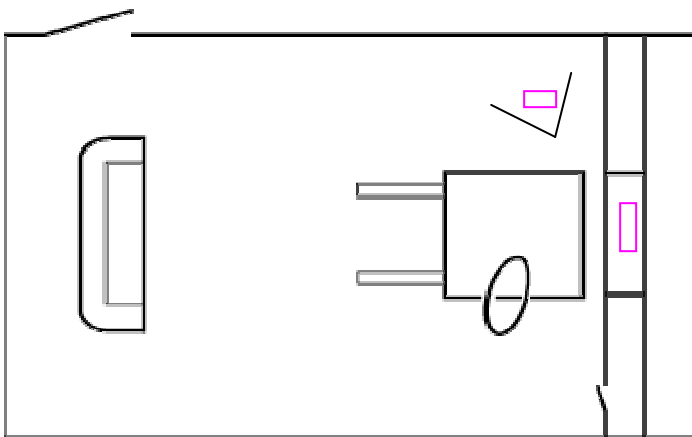

DESCRIPTION	Rectangular plywood or MDF (medium density fiberboard) plates with und written on them in white water base acrylic paint. The plates are used during the performance.
CONDITION	The plates are in good condition.
PREVENTION AND PRESENTATION GUIDELINES	If necessary, the plates can also be recreated by the performer for the performance.

OBJECT	video materials
CODE	N7 (DVD player); N8 (DVD film); U1 (TV monitor)
DIMENSIONS (height x width x depth)	N7: 4 x 43.5 x 23.5 cm U1: 24 x 26 x 29 cm
QUANTITY	N7, N8, U1:1
PHOTOS	



POSITION IN THE INSTALLATION SPACE	The TV is on the ladder. The DVD player and the DVD film are above the radio, on the third level of the control box.
------------------------------------	--

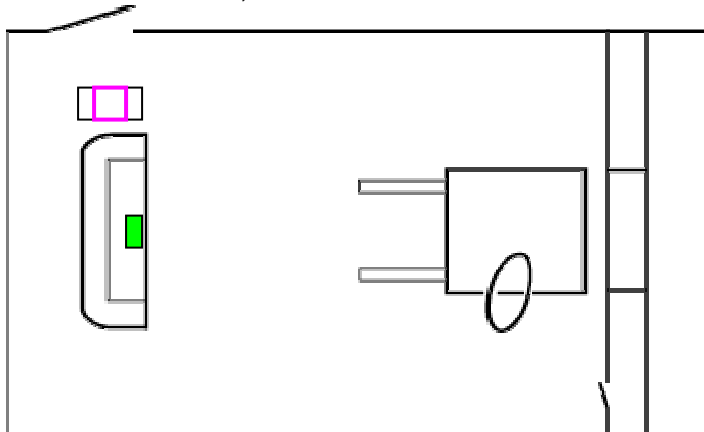

DESCRIPTION	N7: black DVD player PHILIPS (trade name), model no: DVP 632/00, 220 - 240V, 50Hz, 15W. N8: DVD film format (DV PAL 4:3 black & white, no sound, 1h.32min. loop, Suchan Kinoshita). U1: grey surveillance model TV, Monacor (trade name, Germany GMBH & CO), simple color monitor, cathode ray tube system, 10 inch, 230 V, 50Hz, 45V A.
CONDITION	The objects are in good condition. They were dusty, and the dust was removed with a soft brush. There are some scratches and color gaps on the TV.
PREVENTION AND PRESENTATION GUIDELINES	A CRT TV monitor should be used in the future. The artist does not want a flat screen. The present model can be replaced with a similar one. Monacor is still producing new models similar to this (e.g. CDM-1003COL or CDM-

1206). The color is not important. The monitor can be white or black or grey. The important thing is to have a TV monitor that is small and that is positioned in front of the wall. The film does not need to be projected in the space. The current position is the best solution for the artist.

Two small TV monitors that could replace the present one in the future are conserved at the S.M.A.K. (BURLE, trade name, USA, 1997, model TC 1909AX, 220 - 240V, 40W, 50Hz).





OBJECT	window accessories
CODE	B, B1, B2
DIMENSIONS (height x width x depth)	B (window): 100 x 150 cm and 100 x 76 cm ; B1 12 x 160 x 6 cm a curtain with metal lamellenis (closed position - when the store is open, it's as long as the window); B2 102.5 x 148 x 3 cm (elastic window)
QUANTITY	B: 2 hinges for shutters; B1: 1 a curtain with metal lamellenis; B2: 1 elastic window

PHOTOS



POSITION IN THE INSTALLATION SPACE

 store
 elastic window

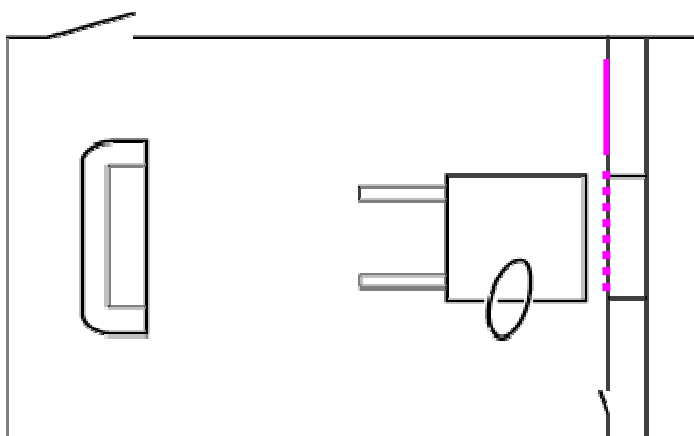

DESCRIPTION

B: 2 fibre board shutters painted white and installed on the window with two metal hinges; B1: 1 green metal lamellenis, each element is tied with a nylon rope; B2: 1 elastic window composed of a wooden frame made with different bars attached by metal plates. Different white elastics are stapled on the frame.

CONDITION

The objects are in good condition.

PREVENTION AND PRESENTATION GUIDELINES

The window with the shutters is newly made with each new installation. The elastic window is used during the performance and placed on the window or hung up on the wall close to the window (on the left) with a square metal hook.

OBJECT	windscreen
CODE	X
DIMENSIONS (height x width x depth)	closed: 191 x 64 x 5 cm
QUANTITY	1
PHOTOS	



POSITION IN THE
INSTALLATION SPACE

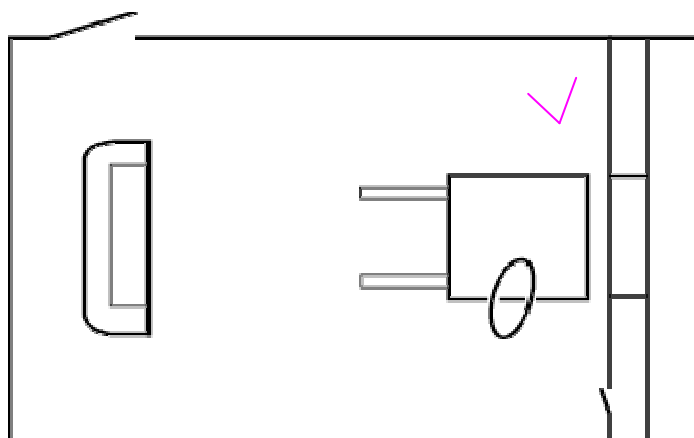

DESCRIPTION	The windscreen is composed of a white textile mounted in a wooden frame. The frame is painted white.
CONDITION	The object is dusty and dirty. There are scratches, splinters and painting gaps on the wooden frame.
PREVENTION AND PRESENTATION GUIDELINES	The position of the object was determined by the artist. The distance from the walls is shown in the room floor plan, layer 5.

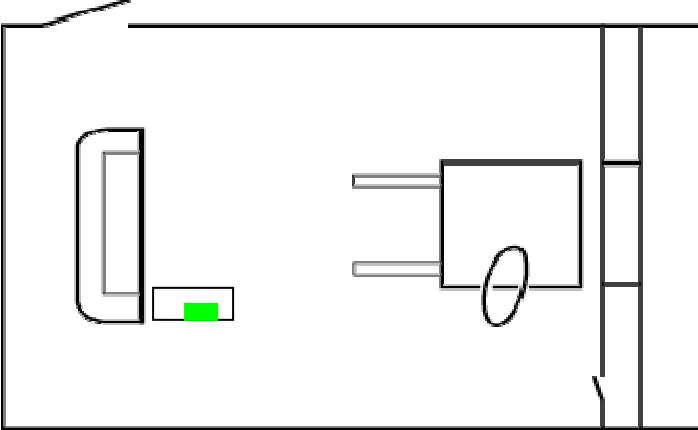
OBJECT	wooden shelf
CODE	J (1 to 23)
DIMENSIONS (height x width x depth)	J (wooden shelf): 16.5 x 59 x 2 cm.
QUANTITY	1 wooden shelf with paraphernalia on it (23 different small objects -see the object list)
PHOTO	
POSITION IN THE INSTALLATION SPACE	
DESCRIPTION	The object is a wooden shelf painted white on the top. There are 23 different small objects on it. Some of these objects are used during the performance and placed on the Lego train. The yellow Lego base for the dust flock has been made to support the flock on the train during the action.
CONDITION	The shelf is dusty and dirty. The edges are worn. The objects on it are also really old and worn.
PREVENTION AND PRESENTATION GUIDELINES	All the paraphernalia can be replaced in conformity to the artist's directions (see conversation with the artist). Their positions on the shelf are not fixed.